

# Long-Term Halogen Measurements at Cape Verde

Ulrich Platt, Udo Frieß, Jessica Balbo

Institut für Umweltphysik, Universität Heidelberg, Germany

- Reactive Halogen Species in the Troposphere
- Previous Work of IUP Heidelberg
- DOAS and MAX-DOAS
- Expectations and Plans ...



University of Heidelberg

Institute for Environmental Physics



# Reactive Halogens in the Atmosphere

## Stratosphere:

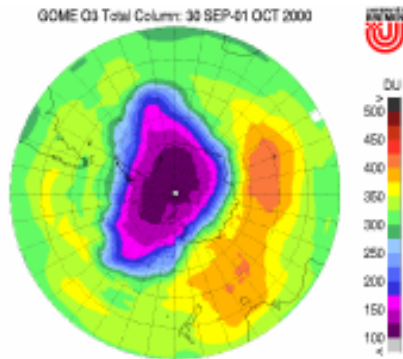

Known since Lovelock,  
Global Strat. Ozone  
Depletion,  
Ozone Hole, ...  
Sources: Longe lived  
organo-halogens

## Stratospheric Ozone destruction

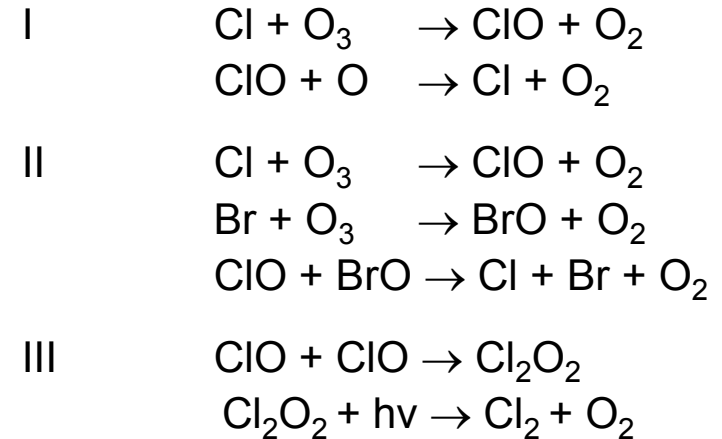

## Troposphere:

Known only since late 1980ies,  
...  
Sources: Short lived organo-  
halogens, Sea salt, Volcanoes,  
...

## Consequences

Ozone destruction, Reduction of Ozone  
formation, Modification of  
oxidation capacity

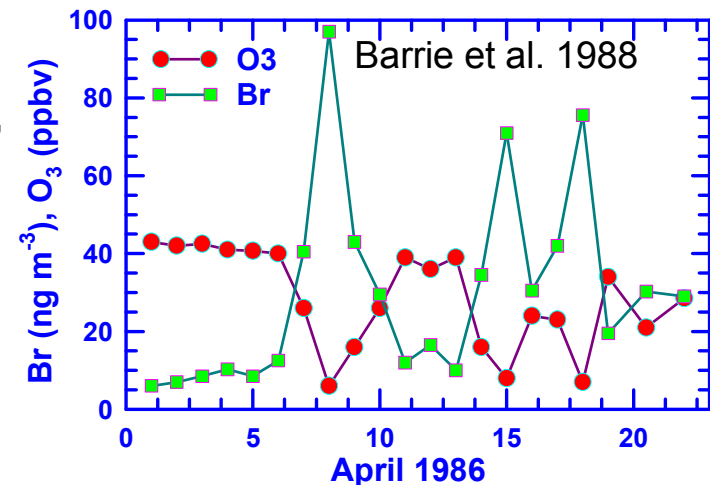

# Simplified Outline of the Tropospheric $XO_x$ -Cycles

$XO_x = X + XO$   
 $X = I, Br, Cl$

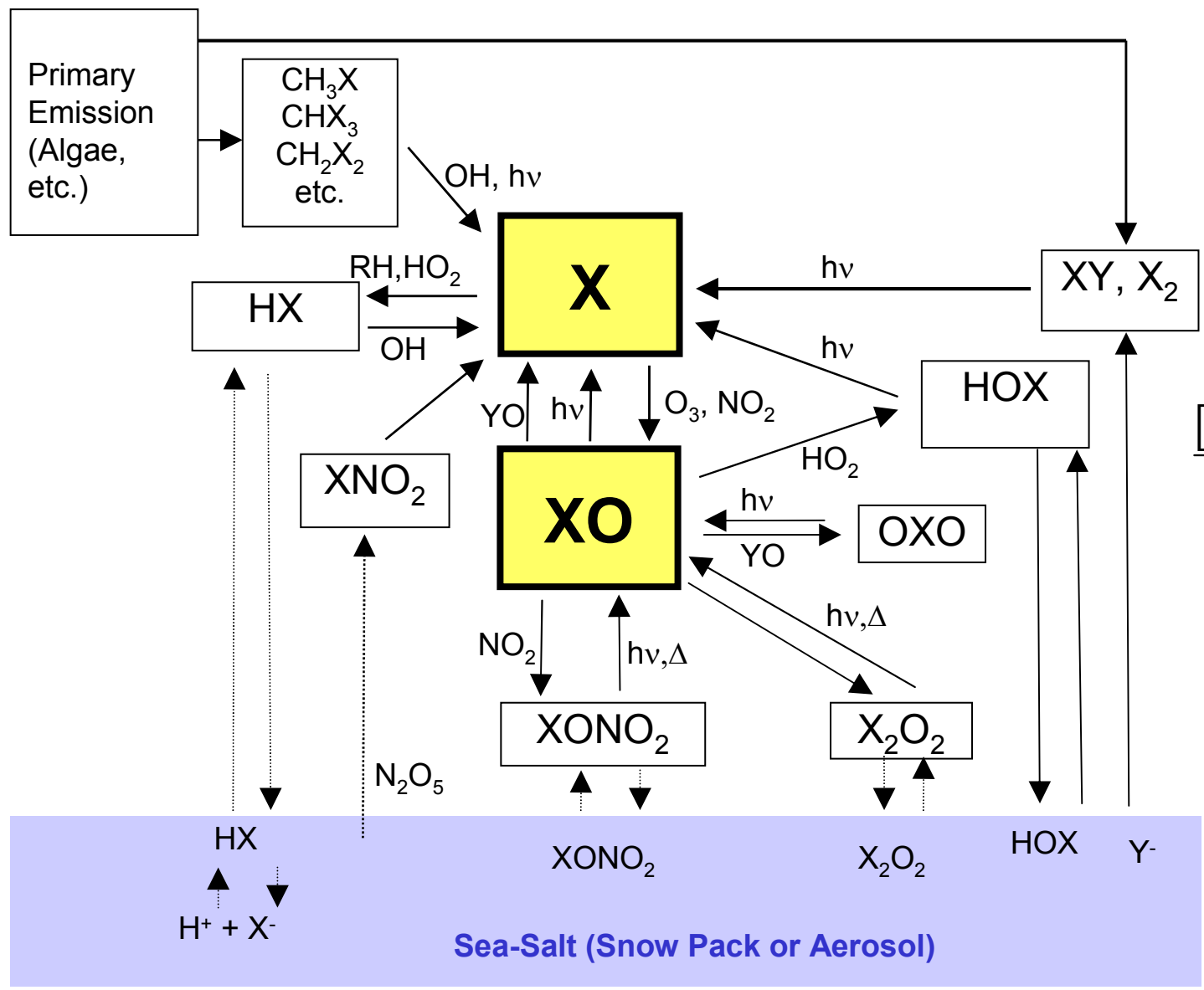

$\frac{[XO]}{[X]} \approx 1000$  (X = Cl),  
 $\approx 100$  (X = Br),  
 $\approx 10$  (X = I)

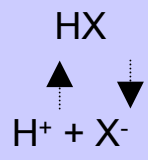

Sea-Salt (Snow Pack or Aerosol)

# Halogen Catalysed Destruction of Tropospheric O<sub>3</sub>

## Homogeneous reactions

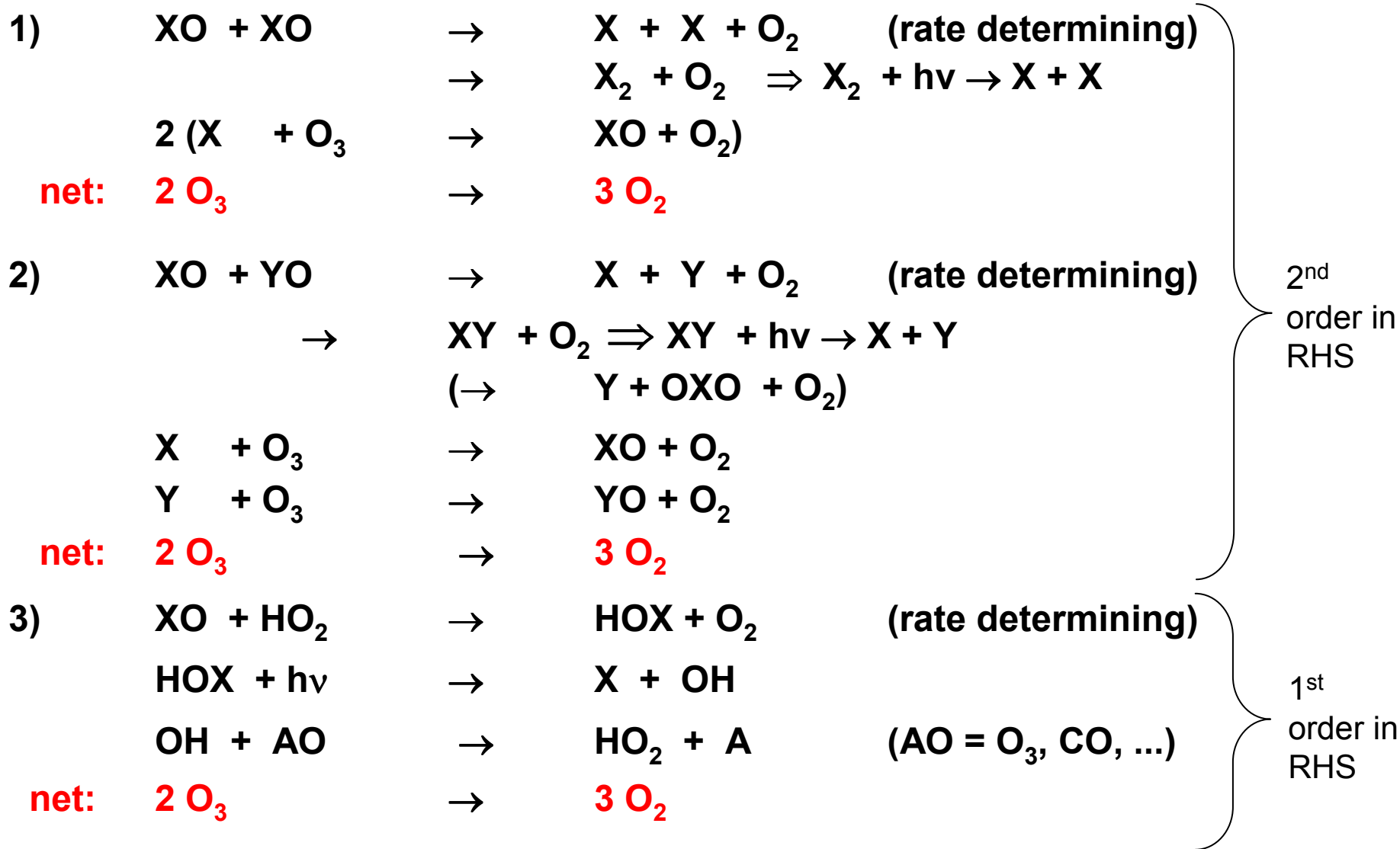

# Impediment of $\text{NO}_x$ and $\text{HO}_x$ Catalysed Tropospheric Ozone Production by Halogen Oxides

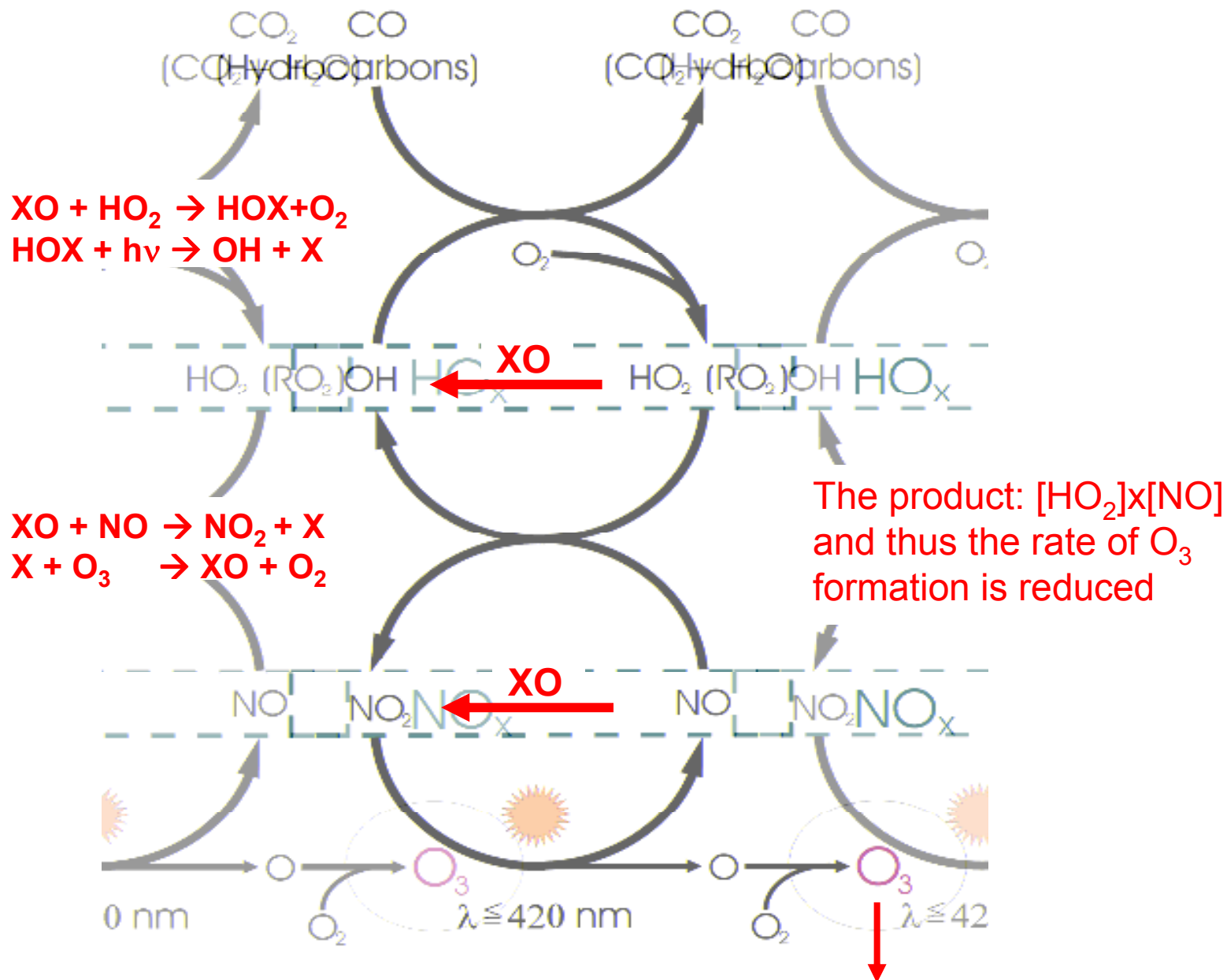

# Tropospheric Halogen 'Domains'

From: v. Glasow & Platt, HitT Description

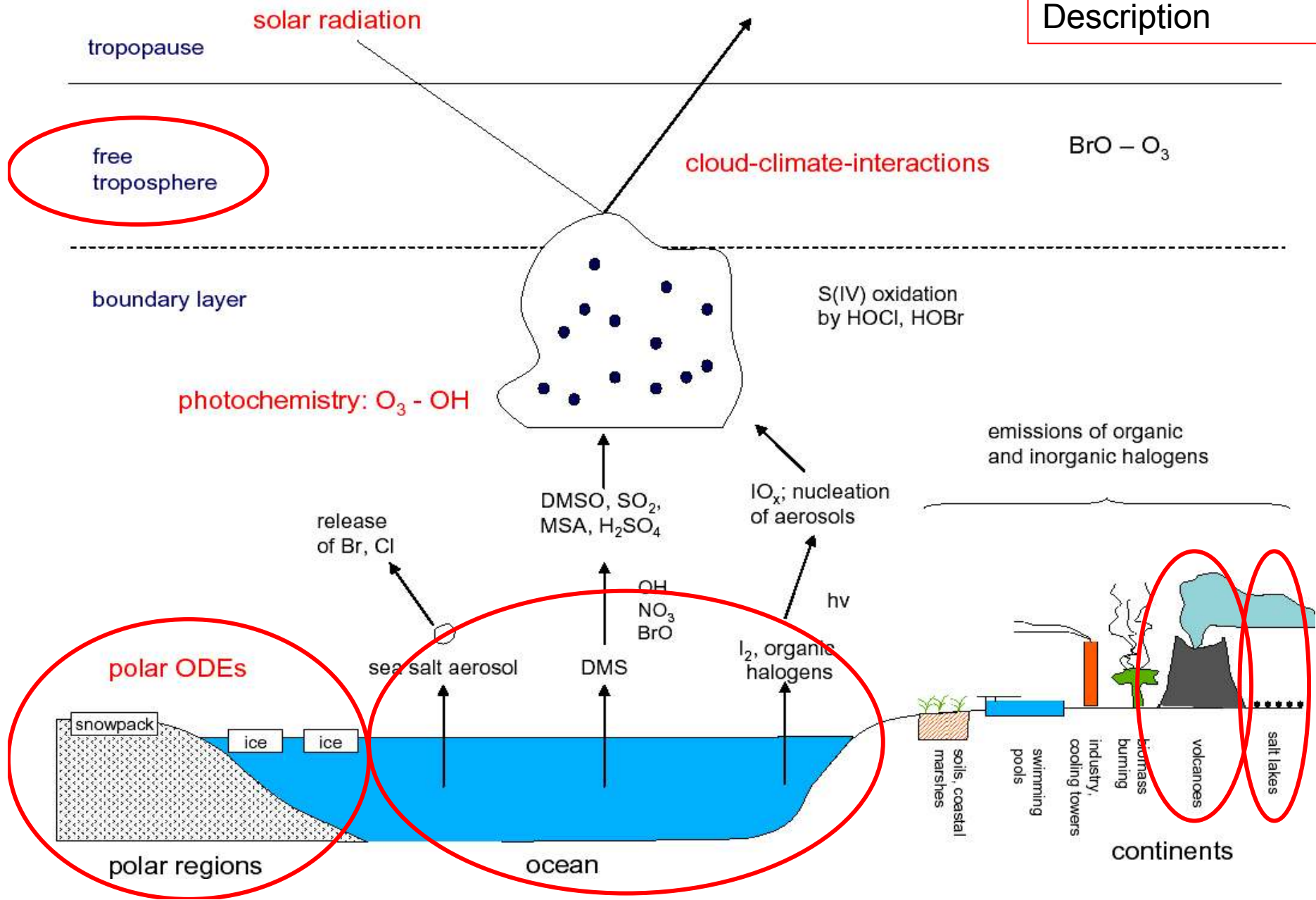

# IO Precursor: CH<sub>2</sub>I<sub>2</sub> or I<sub>2</sub>?

## Data from Mace Head 1998, and Brittany, France, 2003

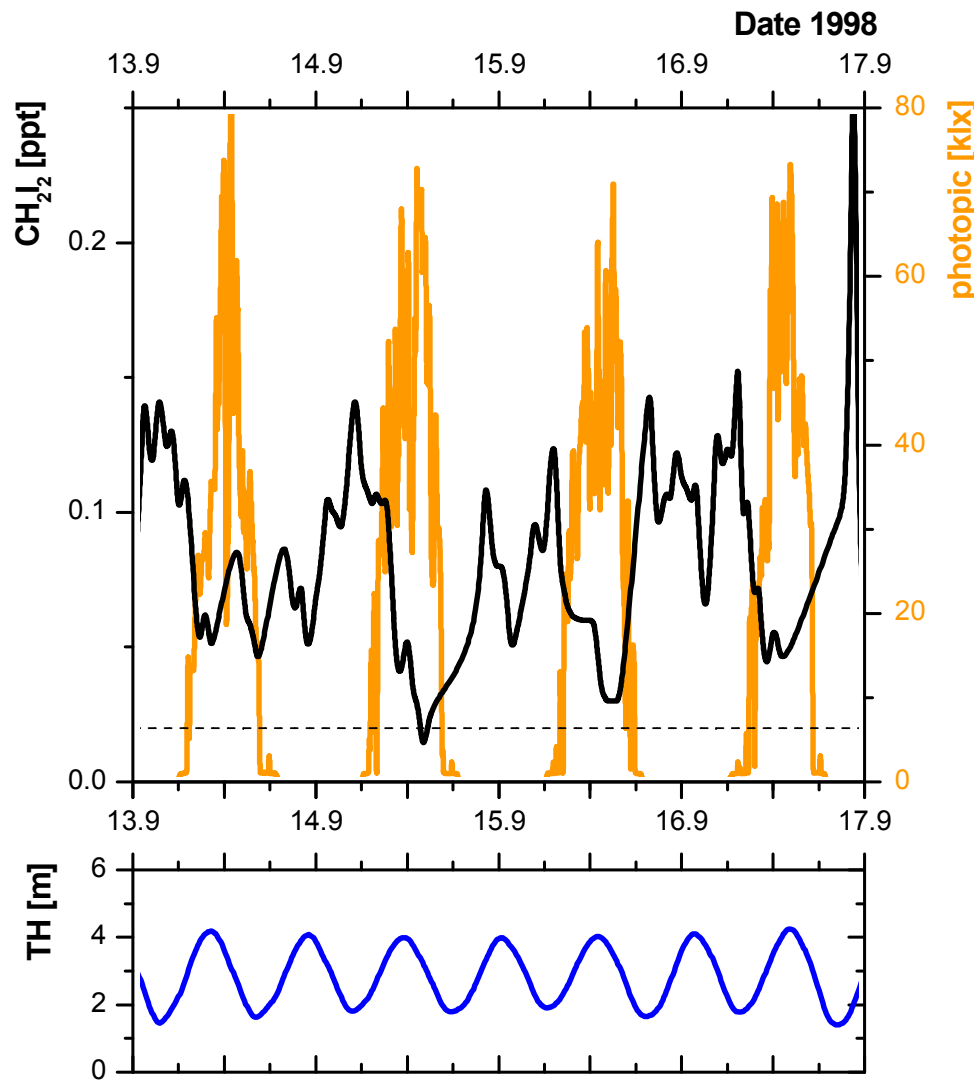

CH<sub>2</sub>I<sub>2</sub> by Lucy Carpenter, taken from Kai Hebestreit Ph. D. Thesis, Univ. of Heidelberg, 2001

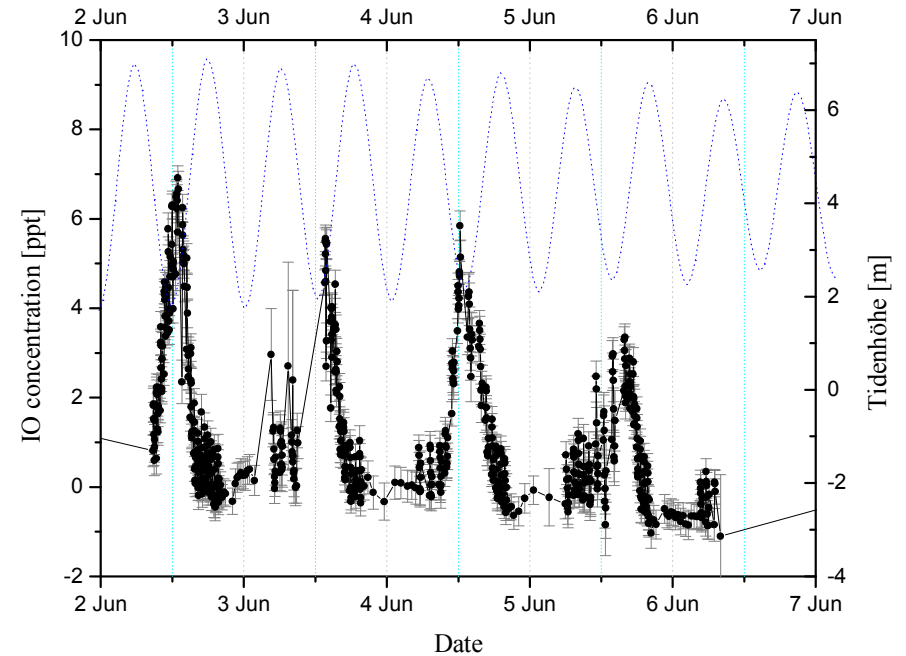

IO at Lilia, Brittany, France, Atlantic Coast  
06.5.2003 - 13.6.2003, C. Peters et al. 2005



# DOAS – Measurements of I<sub>2</sub> at Mace Head, Oct. 1998

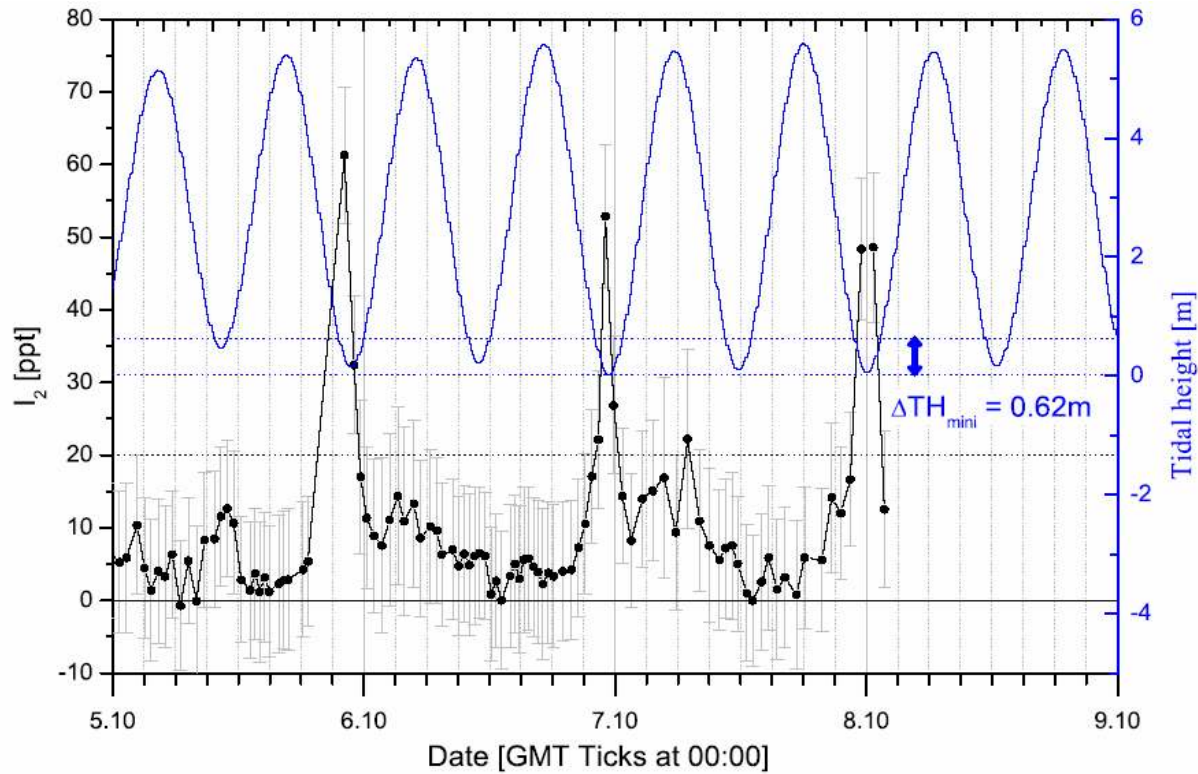

Data from Hönninger et al.,  
re-evaluation by C. Peters

Molecular Iodine is  
only seen at very  
low tide



Forest of  
*Laminaria*  
*Digitata*

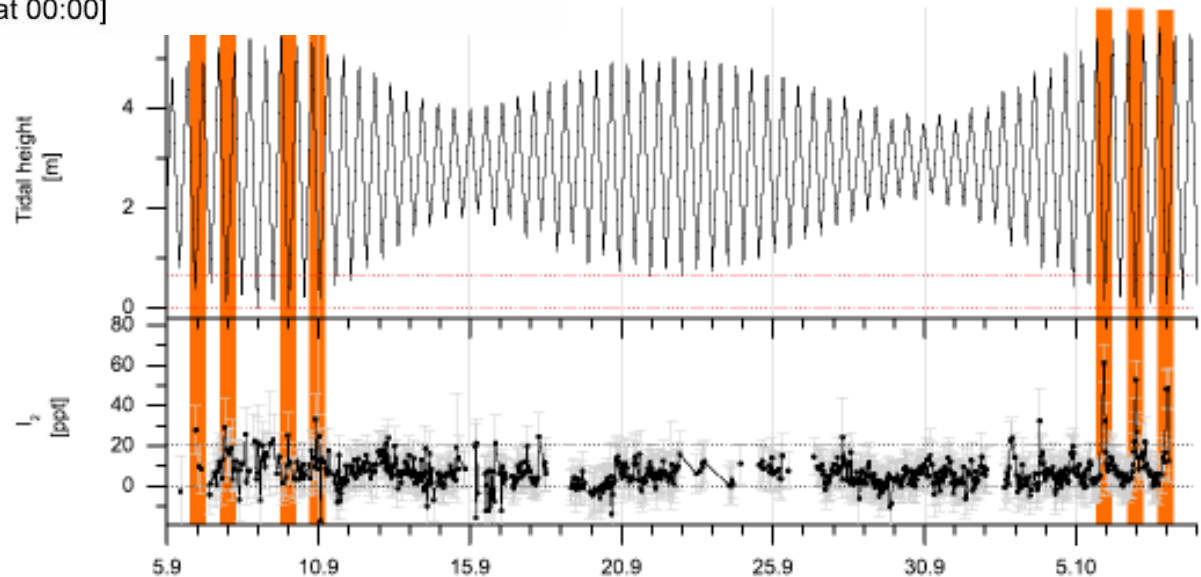

# I<sub>2</sub>, IO, OIO, and BrO during NAMBLEX at Mace Head, 2002

Saiz-Lopez et al.. ACP 6. 2006

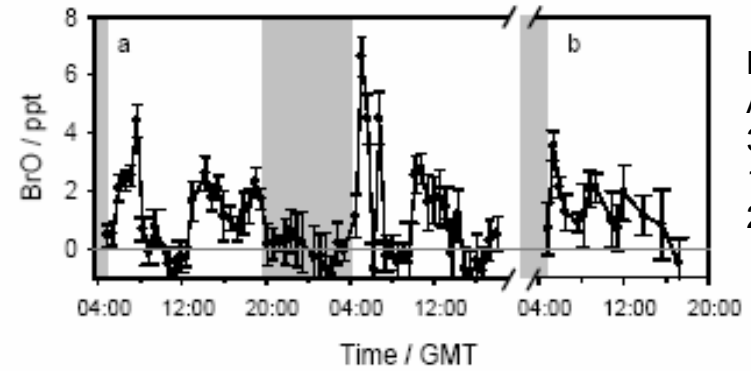
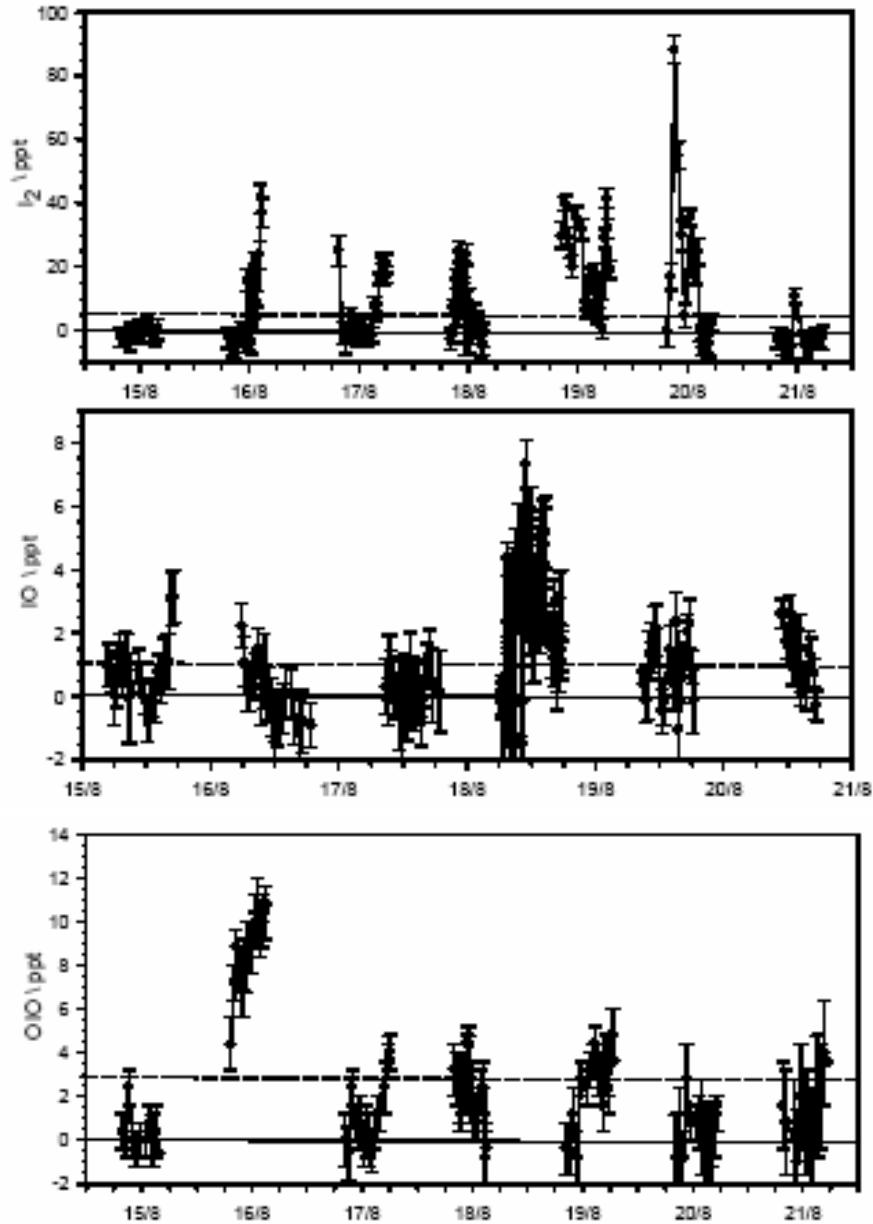

BrO at August 3, 4, 10 of 2002

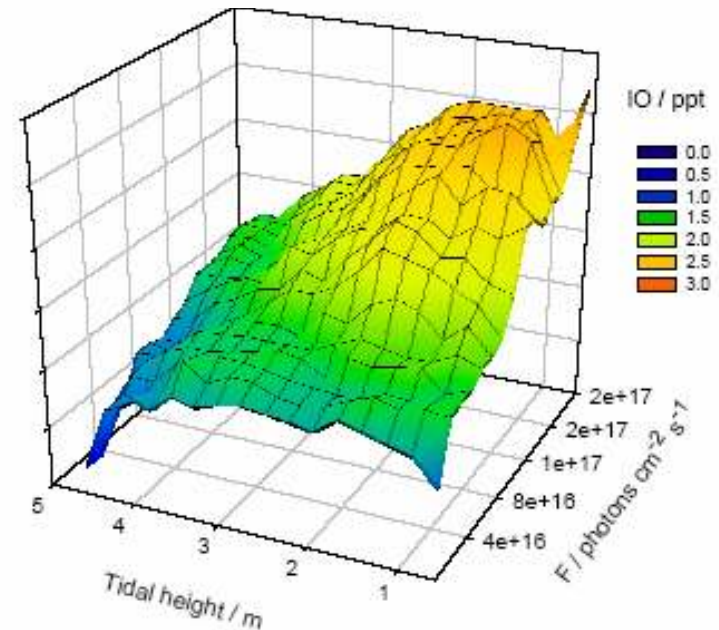
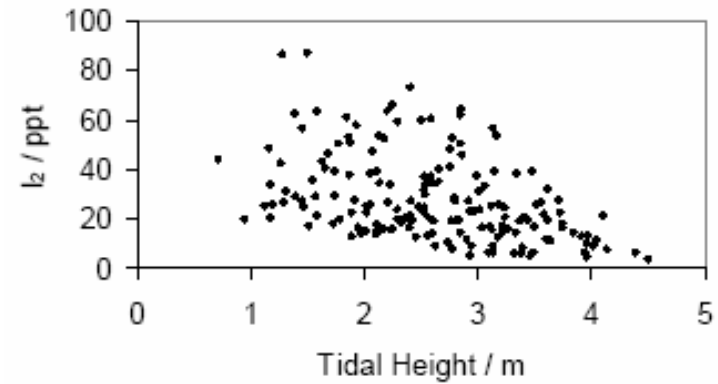

# Summary: Consequences of RHS in the Troposphere

- Catalytic destruction of ozone
- Reduction of the HO<sub>2</sub>/OH ratio
- Enhancement of the NO<sub>2</sub>/NO ratio
- → Potentially strong influence on the global tropospheric ozone budget
- Change of oxidation capacity (e.g. reduction of DMS)
- Primary particle formation (IO<sub>x</sub>)

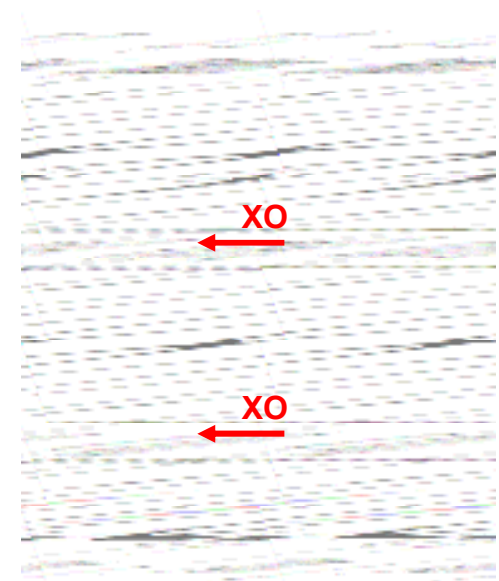

Particle formation: [Hoffmann et al. 2001, Jimenez et al. 2003, Burkholder et al. 2004]:

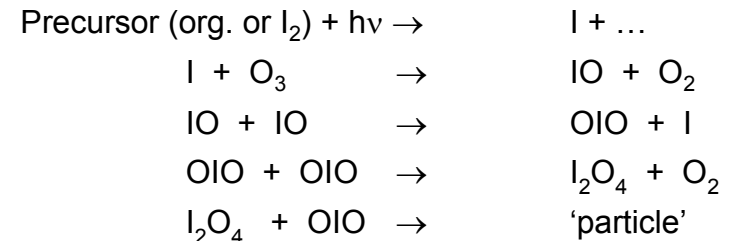

# Preceding Work of our Laboratory Related to RHS in General

Our Group has been involved in Investigations of most experimental aspects of tropospheric RHS including:

- Studies in polar regions (first identification of BrO in the Arctic and Antarctic Boundary Layers)
- Studies at Salt Lakes (first identification of BrO and IO at the Dead Sea and at the Salar de Uyuni)
- Studies in the free troposphere (first direct determination of BrO in the free troposphere by balloon-based spectroscopy)
- Studies at volcanoes (first identification of BrO, ClO, and OClO in volcanic plumes)
- Studies in coastal regions (first identification of IO in a coastal region (Mace Head, Ireland))
- Satellite Studies (first measurement of polar trop. BrO from satellite)
- Identification of the „Bromine Explosion“ Mechanism in polar regions.



# Differential Optical Absorption Spectroscopy (DOAS) – The Idea

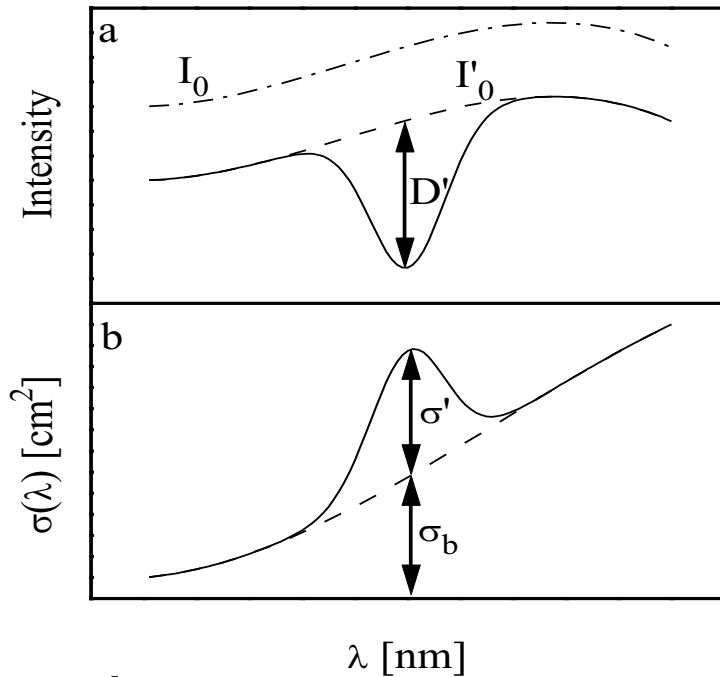

- Use **differences** of intensities at different wavelengths
- Record the intensity in **many** (typ. several 100) wavelength **channels** (entire spectra)
- **High pass-filtering** of spectra  
⇒ remove continuum
- **Fit reference spectra**  
⇒ Make use of all spectral information

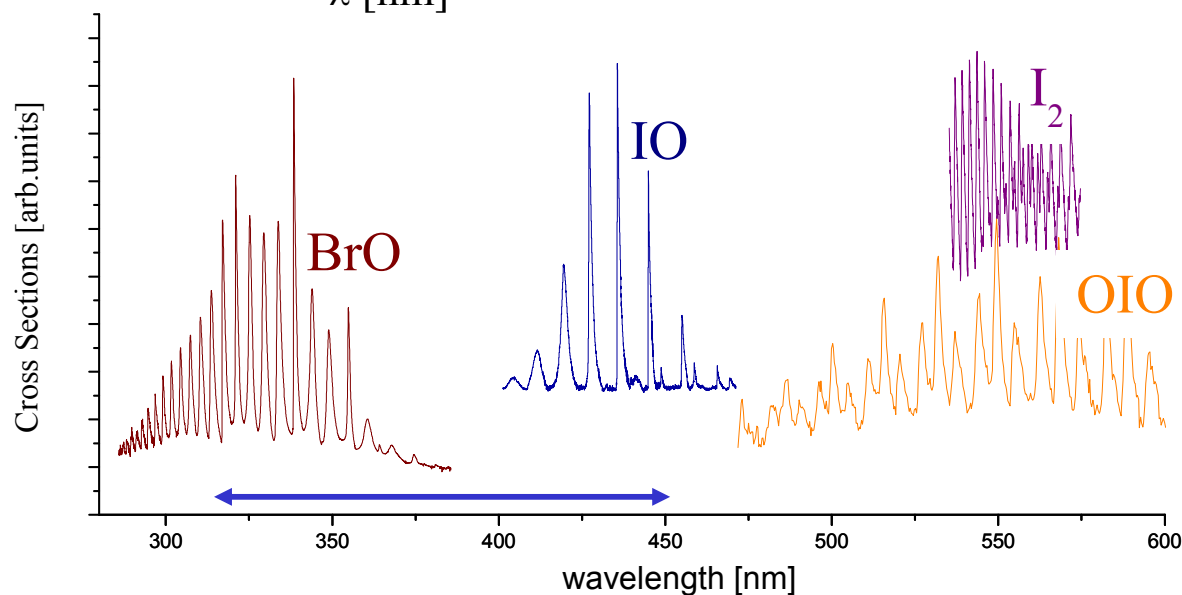

Cabo Verde Spectrometer:  
BrO, IO, NO<sub>2</sub>, CH<sub>2</sub>O

# MAX-DOAS – The Idea

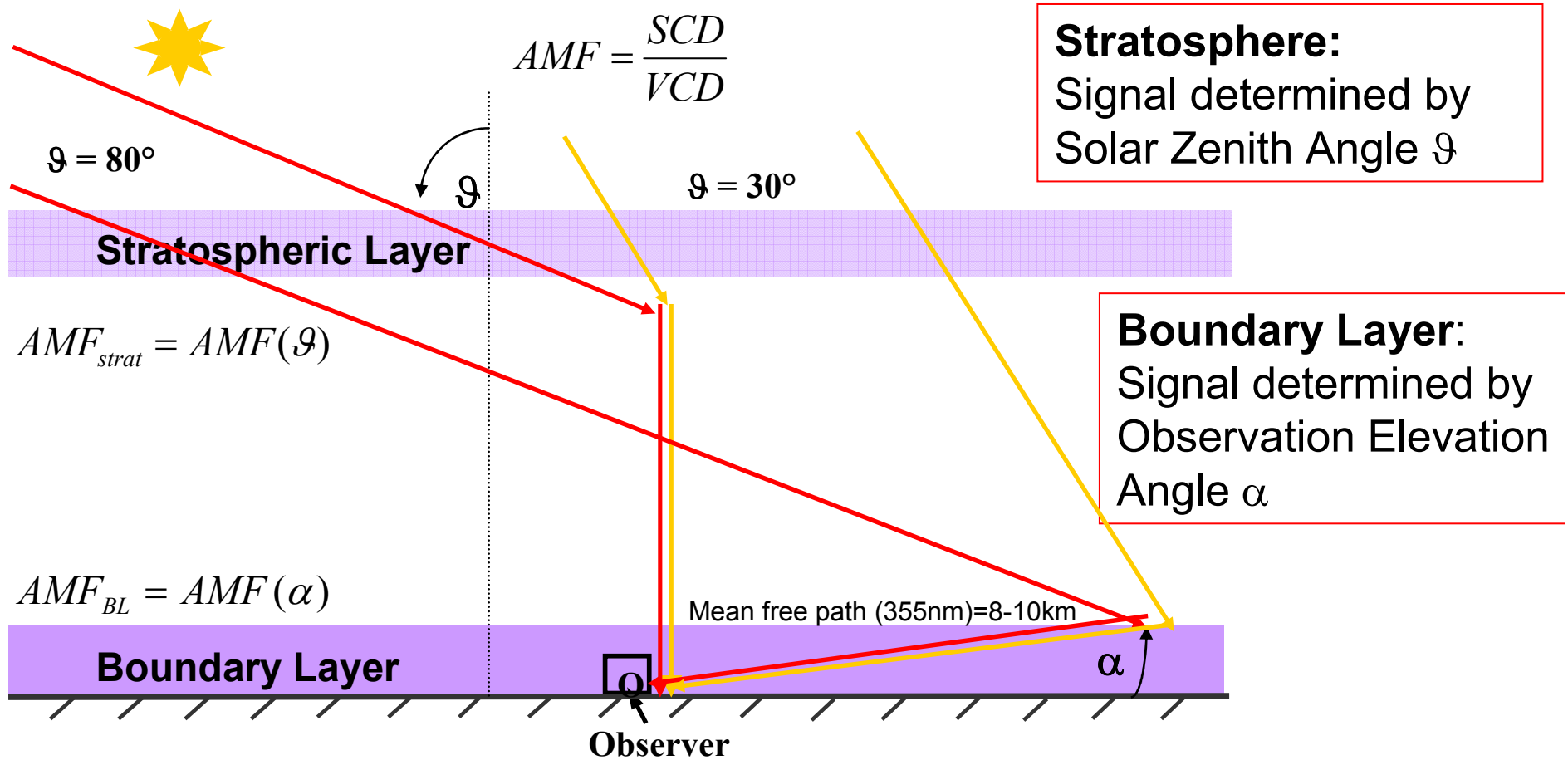

Total Slant Column:

$$S = S_{Trop} \frac{1}{\sin \alpha} + S_{Strat} \frac{1}{\cos \vartheta} = V \cdot \left( a \frac{1}{\sin \alpha} + (1-a) \frac{1}{\cos \vartheta} \right)$$

Hönninger, v. Friedeburg, and Platt,  
Atmos. Chem. Phys. 4, 231–254, 2004

# The Mini – MAX-DOAS Instrument

Cabo Verde Spectrometer:  
BrO, IO, NO<sub>2</sub>, CH<sub>2</sub>O

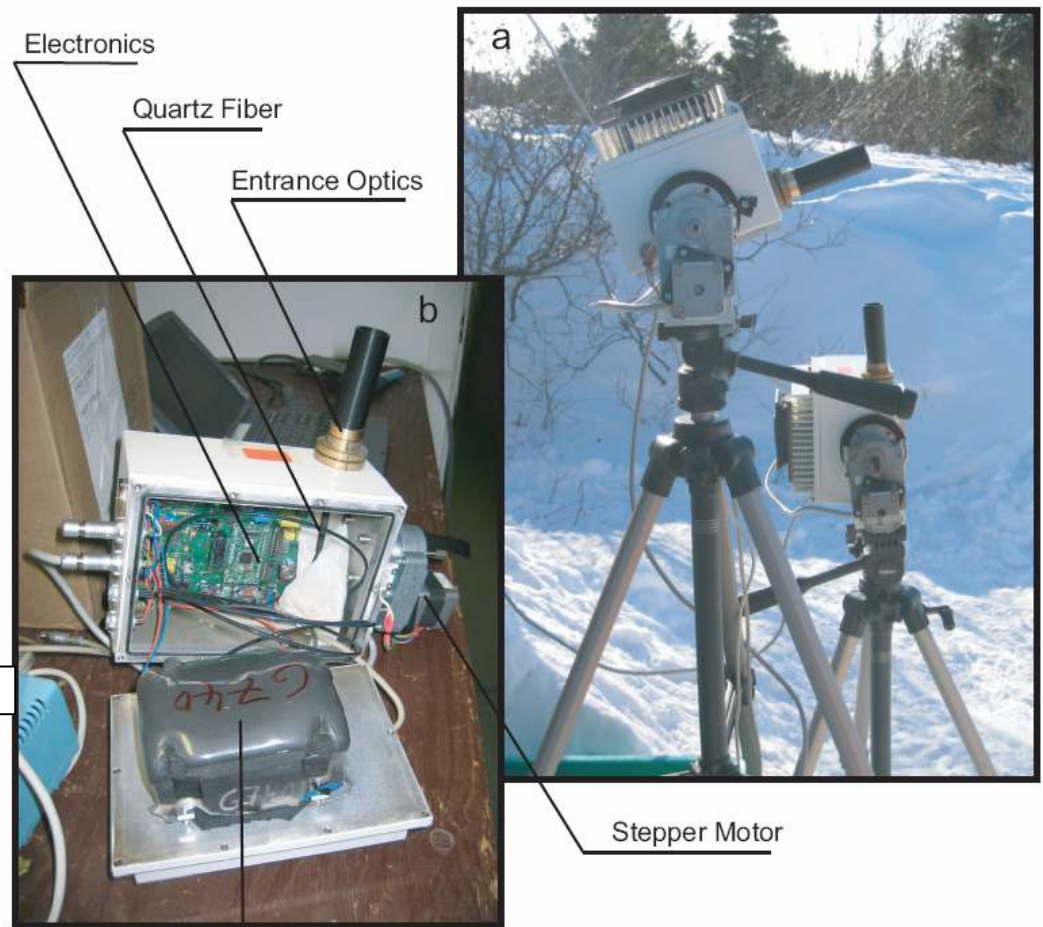
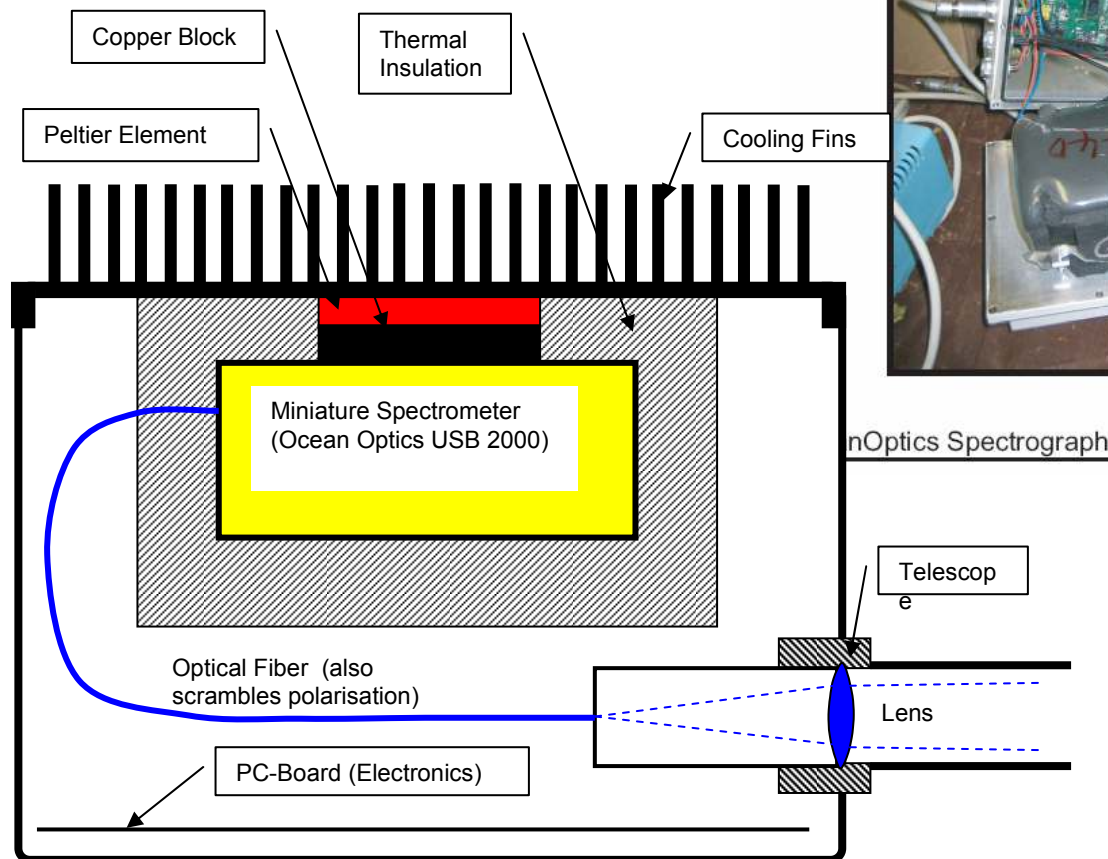

Optics Spectrograph

Telescope  
e

Lens

a

b

Stepper Motor

## MAX - DOAS on the Atlantic (Polarstern, 2000)

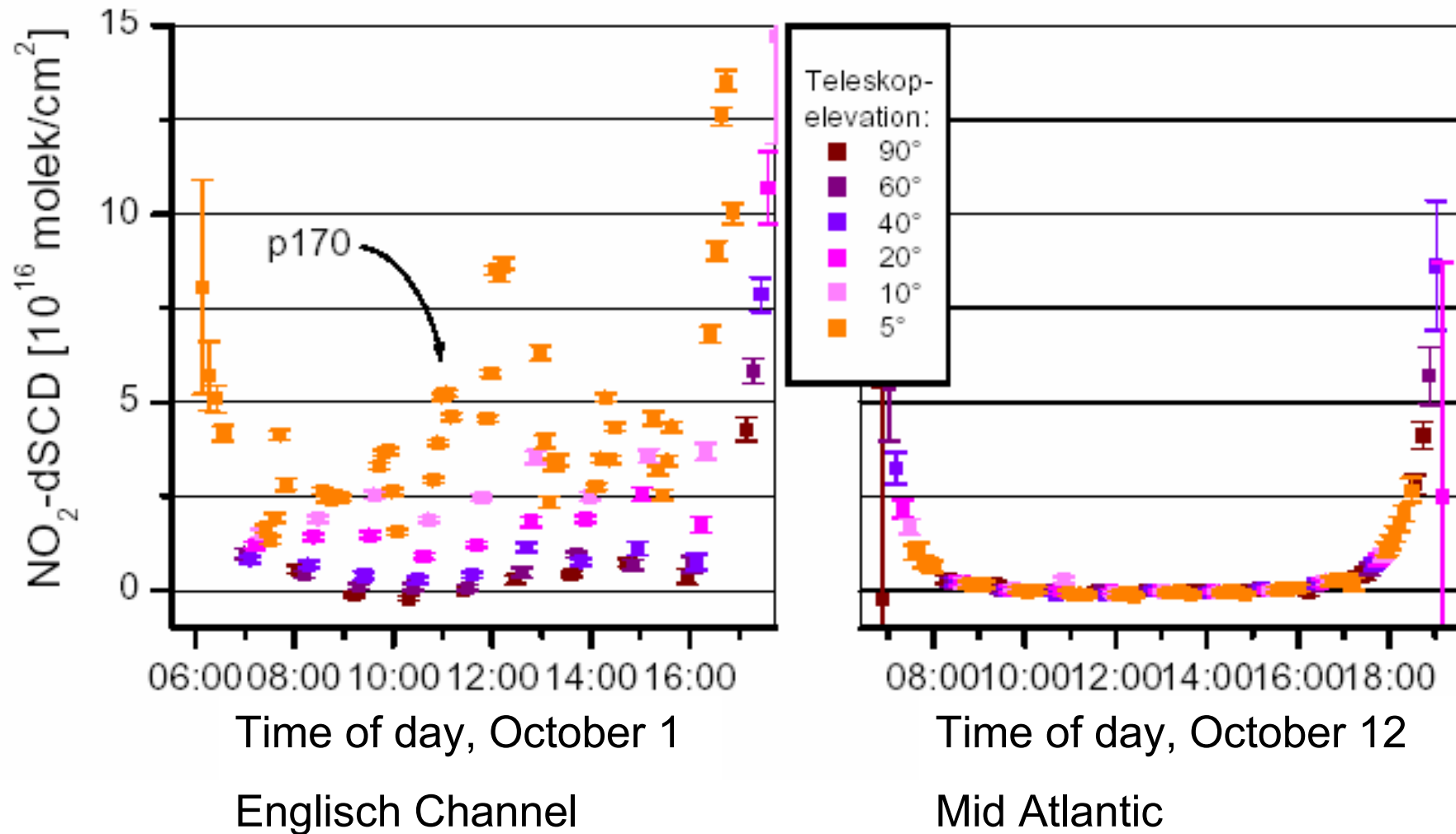

Leser et al., GRL 2003  
doi:10.1029/2002GL015811

# Radiation Transport Considerations for MAX-DOAS Measurements

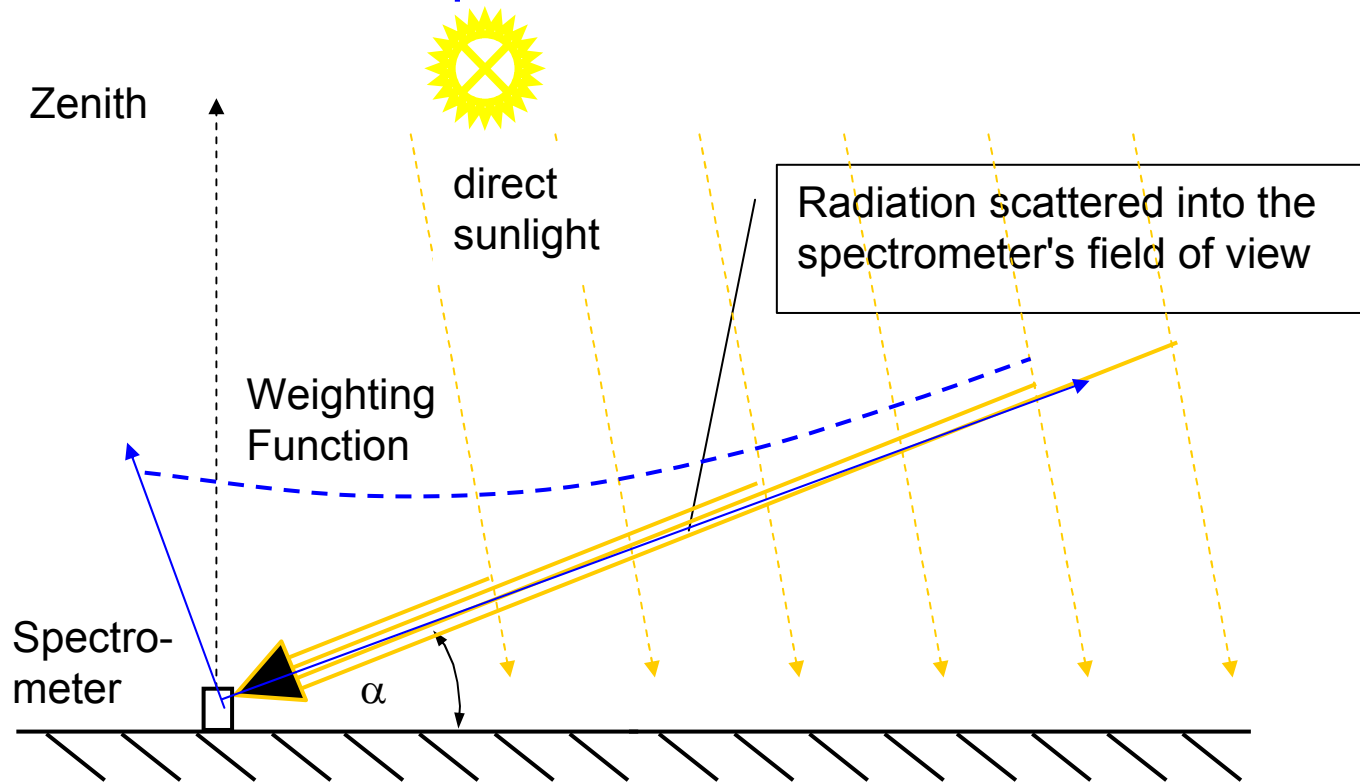

## Shallow trace gas layer:

Strong increase of trace gas column density with decreasing observation elevation angle

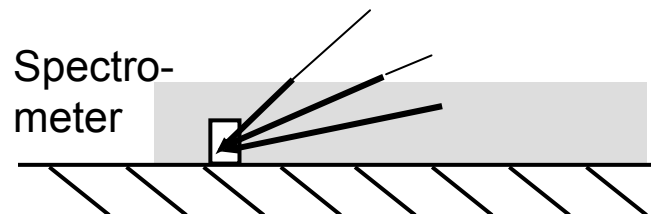

## Deep trace gas layer:

Little increase of trace gas column density with decreasing observation elevation angle

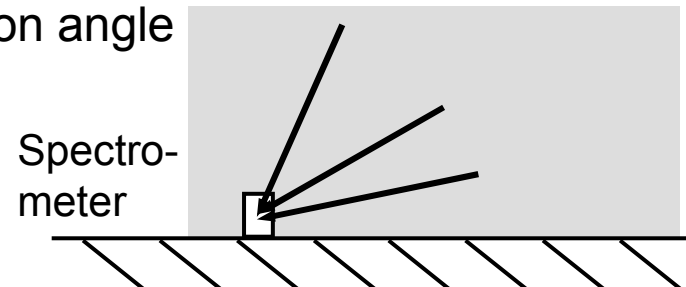

Vertical Resolution of MAX-DOAS --> 'Poor Man's LIDAR'  
 $\Delta$ SCD's Measured on May 4, 2000 (15:15 UT – 15:40 UT), Alert 2000 PSE

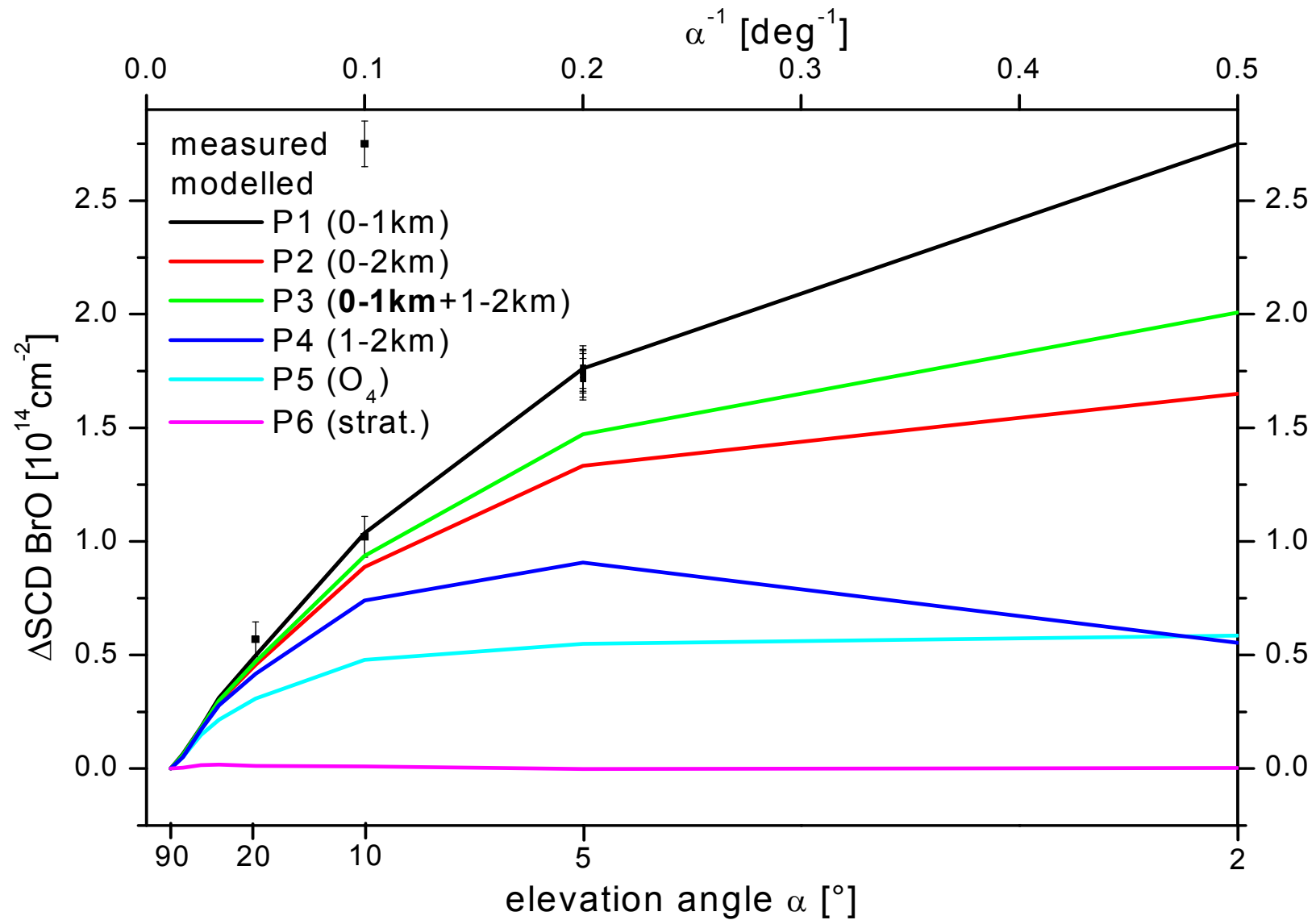

Hönninger and Platt, Atmos.  
Environ. 36, 2481, 2002

## Also Measure Species with Known Abundance, e.g. O<sub>4</sub>

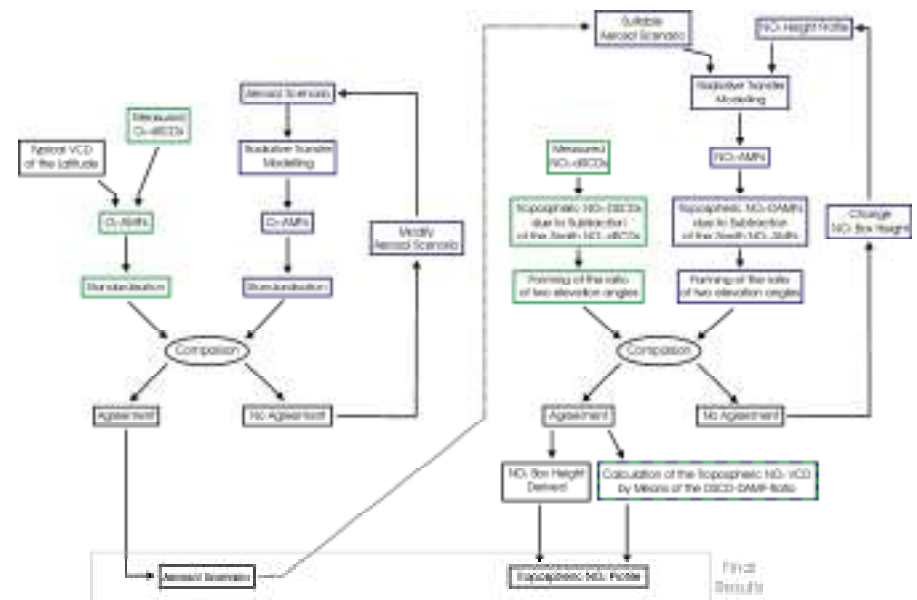
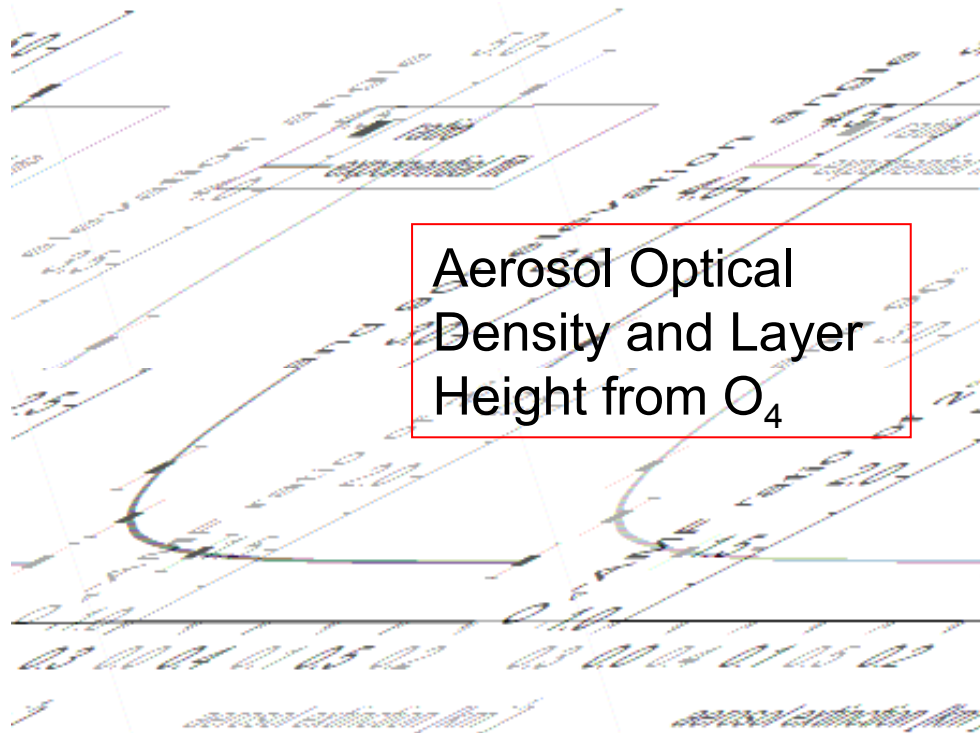

Sinreich et al., Faraday Discuss. 130, 153 - 164, DOI: 10.1039/B419274P, 2005

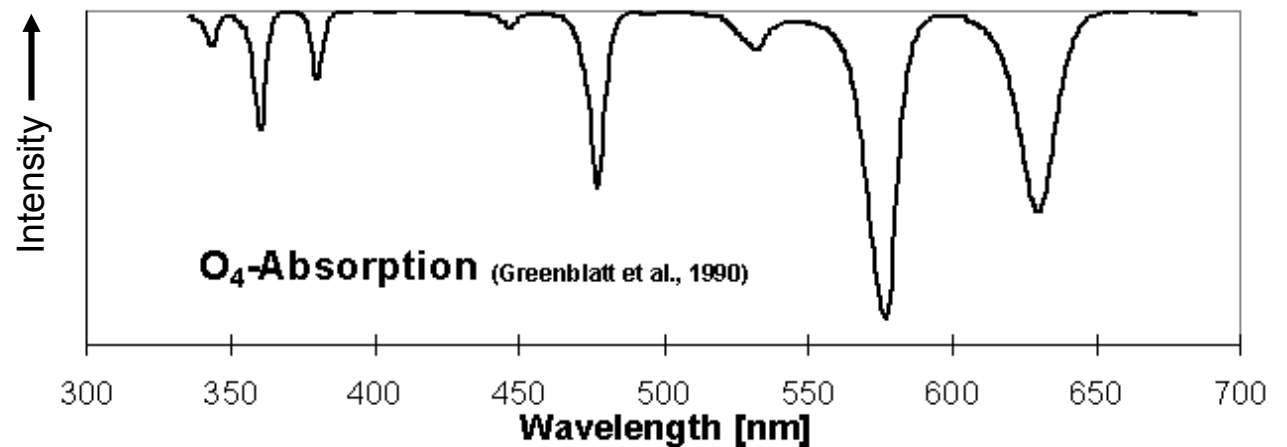

# BrO at Cape Verde, Oct. 28-31, 2006

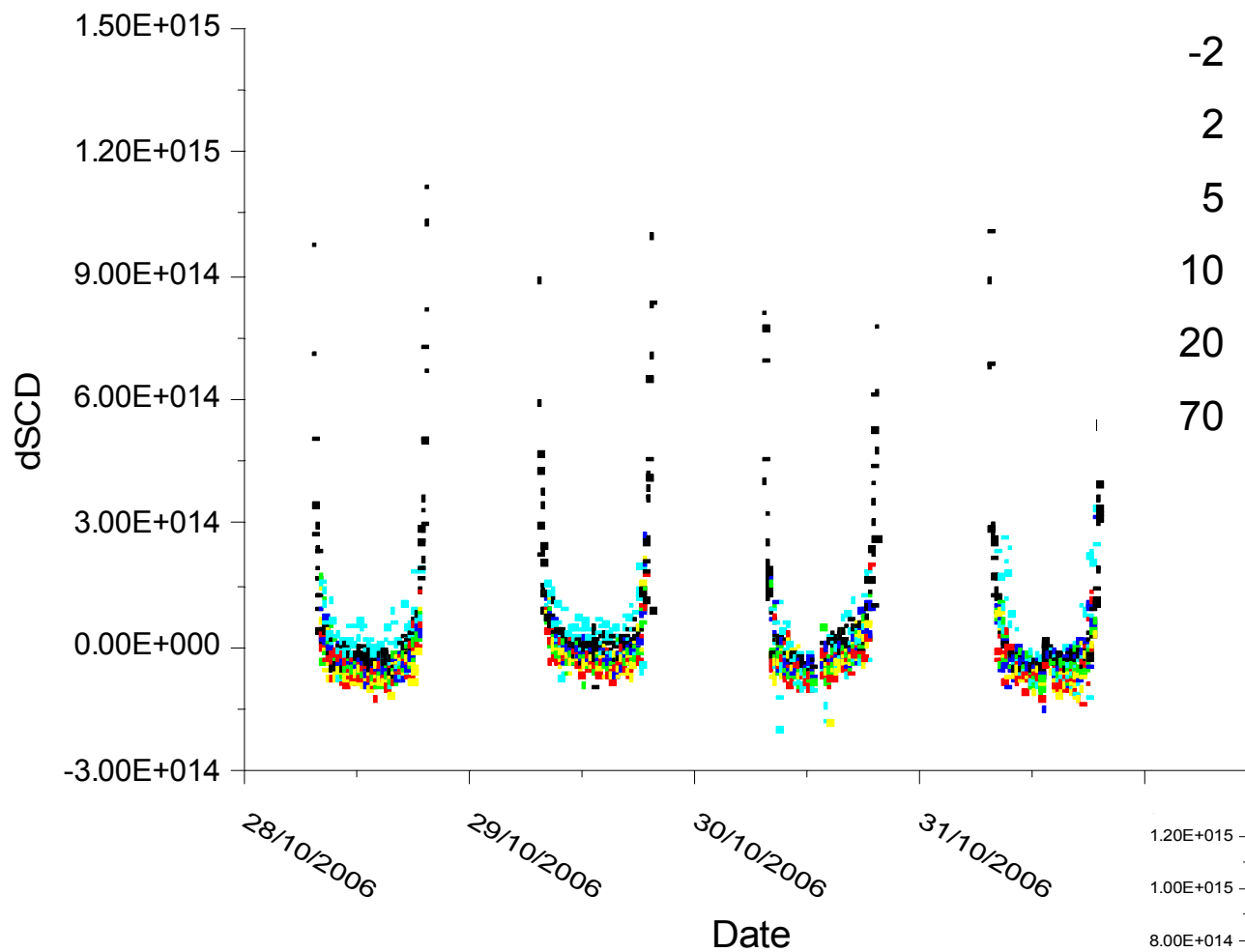

Spectral Range: 330-450 nm

→ NO<sub>2</sub>, BrO, IO (CH<sub>2</sub>O)

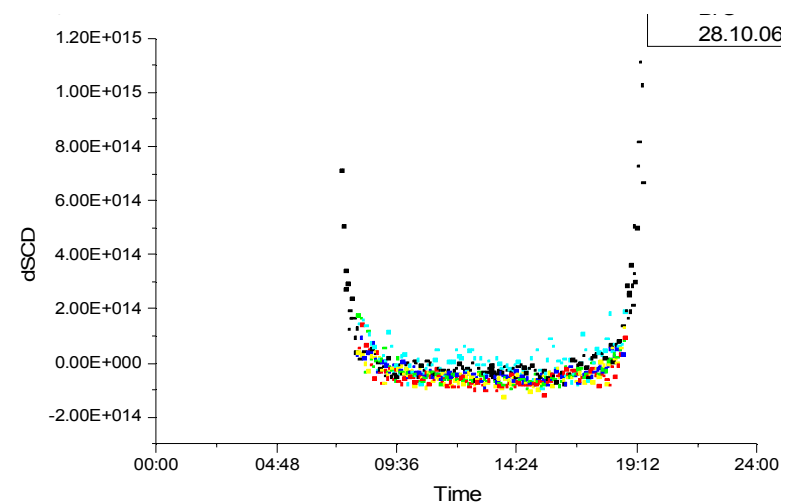

# NO<sub>2</sub> at Cape Verde, Oct. 28-31, 2006

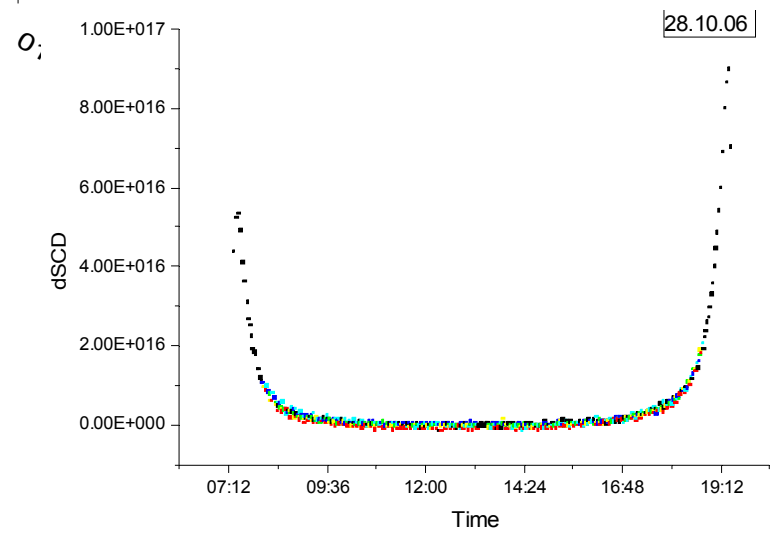
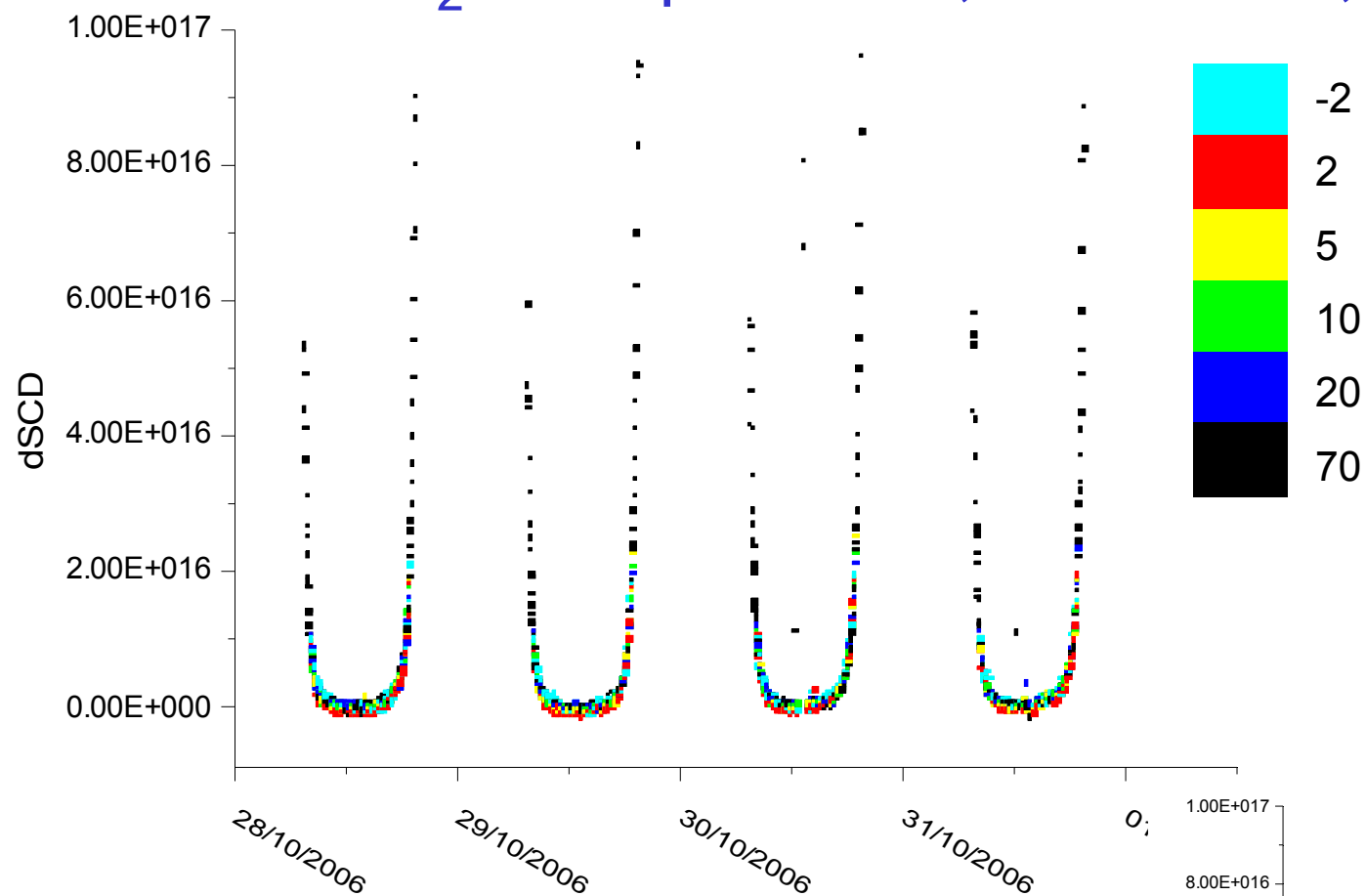

# Questions, Hopes, and Plans ...

## Scientific Questions:

- What is the liberation mechanisms of reactive halogen species from aerosol (and sea water?) ?
- What is the role of Biogenic Sources and the transformation of organo-halogen species?
- What is the role of dust on halogen cycling?
- What is the extend of particle formation from halogen (iodine) precursors?
- What are the possible consequences global change on halogen and other chemistry?
- What are the consequences of tropospheric halogen chemistry on the oxidation capacity of the atmosphere and its impact on climate?

## Observations, e.g.

- BrO, IO  $\Leftrightarrow$  dust correlations
- BrO, IO  $\Leftrightarrow$  correlations with organohalogen levels
- BrO, IO  $\Leftrightarrow$  correlations with biological activity in the ocean

## Future

- Better spectrometer (include I<sub>2</sub>, OIO)
- Dedicated aerosol spectrometer ...